

CX40 Pro

LED Display Controller



Specifications

Change History

Document Version	Release Date	Description
V1.4.1	2024-08-13	Updated certification information.
V1.4.0.B5	2024-05-15	<ul style="list-style-type: none"> • Supports importing 3D LUT files with an accuracy of 33x33x33 / 65x65x65. • Improved document information.
V1.0.1	2023-07-04	<ul style="list-style-type: none"> • Added descriptions for low latency. • Updated the supported driver ICs for frame rate adaptive.
V1.0.0	2023-01-12	First release

Introduction

The CX40 Pro is a 4K LED display controller in the brand-new control system COEX series of Xi'an NovaStar Tech Co., Ltd. (hereinafter referred to as NovaStar). This controller offers rich video input connectors (HDMI 2.0, DP 1.2 and 12G-SDI) and supports 5Gbps output via Ethernet port and 40Gbps remote transmission via optical port.

The CX40 Pro can also work with the brand-new software VMP (Vision Management Platform) to provide a better operation and control experience. Featuring a 5.5-inch touch LCD, it makes user operation and control much easier.

Certifications

CE, FCC, IC

If the product does not have the relevant certifications required by the countries or regions where it is to be sold, please contact NovaStar to confirm or address the problem. Otherwise, the customer shall be responsible for the legal risks caused or NovaStar has the right to claim compensation.

Features

Inputs and Outputs

- 3 types of inputs
 - 2x HDMI 2.0 (with loop through)
 - 1x DP 1.2
 - 2x 12G-SDI (with loop through)
- 12-bit, 10-bit and 8-bit video inputs
- 3 types of outputs
 - 6x 5Gbps Ethernet ports, load capacity up to 9 million pixels
 - 1x 40Gbps optical port
 - 1x SPDIF digital audio port
- 3 types of controls
 - 1x Genlock signal input (with loop through)
 - 2x Ethernet control ports
 - 1x Auxiliary port

Advanced Functions

- 3 independent layers
Support up to 3x 4K layers and layer priority adjustment in Z order.
- Image scaling
Support 4 scaling mode: custom, pixel to pixel, snap to canvas, and fill screen.
- Color Replacement
Support free replacement of any color on the image without affecting the performance of other colors. Replacement of highly saturated colors is recommended for better effect.
- 14Ch Color Correction
Support precise adjustment to hue, saturation and brightness of black, white and the 12 derived standard colors of the red, green and blue primary colors.
- Curves
Support adjustment to the image RGBW mapping curves.
- 3D LUT

- Use the 3D LUT file (.cube) with an accuracy of 17×17×17 / 33×33×33 / 65×65×65 to adjust the colors of the video source.
- **Dynamic Booster**
Real-time analysis and dynamic adjustment are made to each frame to significantly improve the display contrast and image details for better visual experience, and effectively control and lower the display power consumption, extending the service life of the LED screen.
 - **Full Grayscale Calibration**
Work with NovaStar's high-precision calibration system and the C3200 scientific grade camera to generate unique calibration coefficients for each grayscale, ensuring uniformity of each grayscale and dramatically improving the image quality.
 - **HDR**
 - Support HDR10 and comply with the SMPTE ST 2084 and SMPTE ST 2086 standards.
 - Support HLG.
 - **Latency**
 - Support low latency and the controller load capacity is not reduced. The latency at the controller is 0 frame (less than 1 ms) in Send-Only Controller working mode and 1 frame in All-In-One Controller working mode.
 - Support additional latency. Zero to two frames of latency can be added at the controller.
 - **Preset**
For optimal display in various scenarios, users can adjust display parameters such as layers, brightness, color temperature, and gamma ahead of time and save them as presets. Users can save up to 128 customizable presets which can be easily applied or switched with just one click.
 - **No rectangle restriction**
- No rectangle restriction for irregular screens. When calculating resolutions, blank pixels do not count towards the total capacity. The used load capacity of Ethernet ports is the sum of the pixels of all cabinets.
- **Frame Rate Adaptive**
Automatically adapt to video inputs with different frame rates ranging from 23.98 Hz to 240 Hz, and support the automatic calculation of optimal screen parameters based on the input source's frame rate. This ensures that the brightness deviation of the screen remains within 5% across different frame rates. It also supports precise frame rate adjustment in 0.01 Hz increments.
 - **Two working modes**
Support the All-In-One Controller and Send-Only Controller working modes.
 - In the Send-Only Controller mode, the latency can be reduced by one frame.
 - In the All-In-One Controller mode, the layer and scaling functions are available.
 - **Shutter Fit**
Automatically adjusts the driver IC parameters according to the camera shutter angle to fix problems of black lines, grayscale addition, and grayscale loss during camera shooting in xR scenarios.
 - **Frame Multiplication**
 - **Frame interpolation:** Outputs images that are captured from multiple shooting angles with different backgrounds at the same time. Solid green backgrounds can also be inserted to allow for easy post-production adjustments.
 - **Frequency multiplication:** Supports high frame rates of up to 240 Hz. This feature is to accommodate multi-angle camera shooting to improve the screen performance under the camera.

Device Controls

- **Touch LCD**
Come with a 5.5-inch 1080p touch LCD. It is sensitive and rugged, allowing users to control the device easily by tapping on the LCD.
- **Support SNMP protocol.**
- **VMP software control**
The device can be connected to the VMP software to provide easy and convenient operations and smart device management.
- **Cascading control via Ethernet**
The Gigabit Ethernet control ports support TCP/IP protocol and star topology. No switch or router is needed to deploy multiple devices on the same LAN via device cascading as the network switching function is already built in.
- **Automated system monitoring and alarm**
Hardware monitoring capabilities that encompass fan speed, module temperatures, voltage levels, and operational status. It automatically detects and reports any device faults or alarm information, ensuring real-time monitoring of the LED screen's operational

status.

Table 1-1 Function Limitations

Function	Limitation
Frame Rate Adaptive	To use this function, it is required to pair with the CA50E or XA50 Pro receiving cards and specific driver ICs (for detailed IC models, please see the product specifications on the NovaStar website at https://www.novastar.tech/). Additionally, you must use the Cabinet Tool provided by NovaStar to adjust the driver IC parameters for different frame rates, which will generate the required NCP file.
Dynamic Booster	It is required to work with the CA50E or XA50 Pro receiving cards and users need to use a CA410-VP427, CA410-P427, or CA410-P427H colorimeter to perform the gamut and brightness correction.
Full Grayscale Calibration	It is required to work with the CA50E or XA50 Pro receiving cards and users need to use a C3200 camera to perform the full-grayscale calibration.
HDR	Supports automatic parsing and manual setting of HDR. For 12G-SDI, DP1.2, and non-standard HDR sources, they can only be set to HDR properties manually.
Low Latency	Low Latency cannot be enabled simultaneously with Genlock and Frame Multiplication. Moreover, it is recommended to ensure all Ethernet ports load the cabinets vertically and share the same Y coordinate (all set to 0) when Low Latency is enabled.
VMP Control	To ensure compatibility, the CX40 Pro V1.4.0.B5 must be paired with VMP V1.4.0.CTM0212. The CX40 Pro can be directly upgraded to V1.4.0.B5, but downgrading after the upgrade will not be possible. Due to some user configurations being incompatible between the previous and new firmware versions, after upgrading the CX40 Pro firmware to V1.4.0.B5, you need to perform a factory reset on the controller's LCD screen and choose the "Reset All" option.

Table 1-2 Supported Receiving Card Models

Receiving Card Model	Supported
CA50E	Only V1.3.0.0 or later is supported.
XA50 Pro	Yes

Appearance

Front Panel

Running Indicator Standby Button

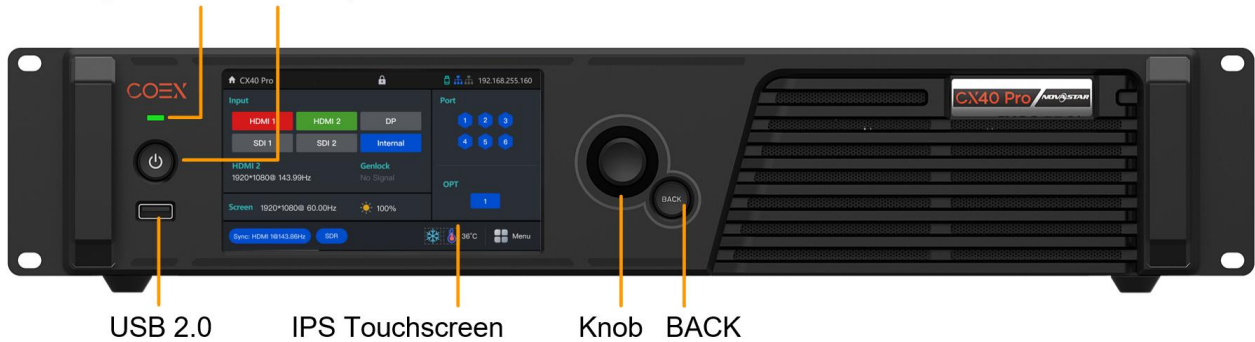

USB 2.0

IPS Touchscreen

Knob

BACK

Name	Description
Running Indicator	<ul style="list-style-type: none"> • Solid red: Standby • Solid blue: The device is being started. • Solid green: The device is running normally. • Flashing red: The device is running abnormally.
Knob	<ul style="list-style-type: none"> • On the home screen, press the knob to enter the menu screen. • On the menu screen, rotate the knob to select a menu item or adjust the parameter value. Press the knob to confirm the operation.
BACK	Go back to the previous menu or cancel the current operation.
Combination Key	<p>Press and hold the knob and BACK button for 5 seconds or more to lock/unlock the touchscreen and buttons.</p> <p> Note:</p> <p>You can lock the touchscreen by using the combination key or the power-off button. The default option is the combination key. You can change the settings on the device's touchscreen. For more detailed instructions, please refer to the <i>CX40 Pro LED Display Controller User Manual</i>.</p>
Power-off Button	<ul style="list-style-type: none"> • When unlocked, press this button to lock the touchscreen and buttons. • If you choose to lock the touchscreen with the power-off button, pressing it again will display a pop-up window allowing you to choose whether to power off the device. Pressing and holding the power button for 5 seconds or more will restart the device. • If you choose to lock the touchscreen with the combination key, pressing and holding the combination key for 5 seconds or more will display a pop-up window allowing you to choose whether to power off the device.
USB 2.0	<ul style="list-style-type: none"> • Connect to the USB drive only to export the device diagnostic result. • Only the NTFS and FAT32 file systems are supported. Others are not supported.
IPS Touchscreen	A 5.5-inch screen that is for displaying the device status, setting parameters, and sending commands.

Rear Panel

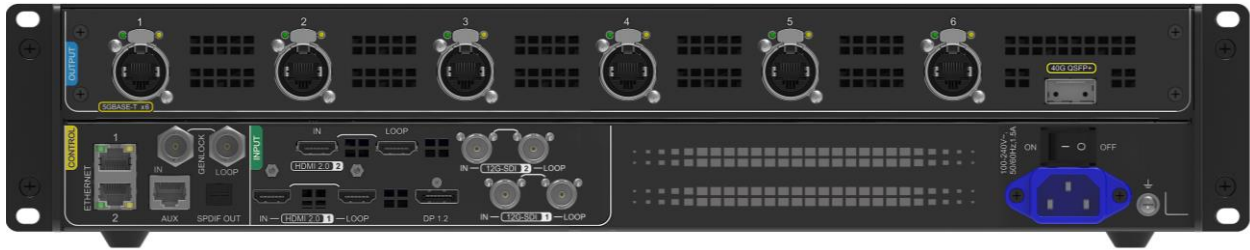

Inputs			
Type	Qty	Description	
HDMI 2.0-1 IN	1	Resolutions	Max resolution: 4096x2160@60Hz Min resolution: 800x600@60Hz
		Max width/height (Forced)	Max width: 8192 pixels (8192x1080@60Hz) Max height: 8192 pixels (1080x8192@60Hz)
		Frame rates	23.98 / 24 / 25 / 29.97 / 30 / 47.95 / 48 / 50 / 59.94 / 60 / 71.93 / 72 / 75 / 100 / 119.88 / 120 / 143.86 / 144 / 240 Hz
		HDR	Support HDR10 and comply with the SMPTE ST 2084 and SMPTE ST 2086 standards. Support HLG.
		EDID management	Support standard resolutions, up to 3840x2160@60Hz. Support custom input resolutions.
		HDCP	HDCP 2.2 compliant, backwards compatible with HDCP 1.4/HDCP 1.3.
		Interlaced signal inputs	Not supported
HDMI 2.0-2 IN	1	Resolutions	Max resolution: 4096x2160@60Hz Min resolution: 800x600@60Hz
		Max width/height (Forced)	Max width: 8192 pixels (8192x1080@60Hz) Max height: 7680 pixels (1080x7680@60Hz)
		Frame rates	23.98 / 24 / 25 / 29.97 / 30 / 47.95 / 48 / 50 / 59.94 / 60 / 71.93 / 72 / 75 / 100 / 119.88 / 120 / 143.86 / 144 / 240 Hz
		HDR	Support HDR10 and comply with the SMPTE ST 2084 and SMPTE ST 2086 standards. Support HLG.
		EDID management	Support standard resolutions, up to 3840x2160@60Hz. Support custom input resolutions.
		HDCP	HDCP 2.2 compliant, backwards compatible with HDCP 1.4/HDCP 1.3.
		Interlaced signal inputs	Not supported
DP 1.2	1	Resolutions	Max resolution: 4096x2160@60Hz Min resolution: 800x600@60Hz

		Max width/height (Forced)	Max width: 8192 pixels (8192x1080@60Hz) Max height: 8192 pixels (1080x8192@60Hz)
		Frame rates	23.98 / 24 / 25 / 29.97 / 30 / 47.95 / 48 / 50 / 59.94 / 60 / 71.93 / 72 / 75 / 100 / 119.88 / 120 / 143.86 / 144 / 240 Hz
		HDR	HDR video is accepted with manual HDR configuration in VMP.
		EDID management	Support standard resolutions, up to 3840x2160@60Hz. Support custom input resolutions.
		HDCP	HDCP 1.3 compliant
		Interlaced signal inputs	Not supported
12G-SDI IN	2	Standards	Support ST-2082 (12G), ST-2081 (6G), ST-424 (3G) and ST-292 (HD) standard video inputs. Support 3G-Level A/Level B (DS mode).
		Resolutions	Max resolution: 4096x2160@60Hz Min resolution: 720x480i@59.94Hz
		Frame rates	23.98/24/25/29.97/30/47.95/48/50/59.94/60 Hz
		HDR	HDR video is accepted with manual HDR configuration in VMP.
		Interlaced signal inputs	Support interlaced signal inputs, including 1080i/576i/480i.
		Cables	Recommend using the CANARE-12G SDI coaxial cable. Cables up to 50 meters are supported.
Outputs			
Type	Qty	Description	
Ethernet ports 1–6	6	5Gbps Ethernet ports <ul style="list-style-type: none"> • Max device load capacity: 9 million pixels • The maximum load capacity per port is as follows. For details, see the Ethernet Port Load Capacity section. <ul style="list-style-type: none"> – 8bit@60Hz: 2,951,200 pixels – 10bit@60Hz: 2,213,200 pixels – 12bit@60Hz: 1,475,600 pixels <p> Note:</p> <p>The device can only reach its maximum load capacity when the load width of a single port is 192 or greater. If the load width is smaller, some of the load capacity will be lost.</p>	
Optical port	1	40Gbps optical port	
HDMI 2.0 LOOP	2	HDMI loop through. Up to 8 devices can be cabled in one loop.	
12G-SDI LOOP	2	SDI loop through. Up to 8 devices can be cabled in one loop.	
SPDIF OUT	1	A digital audio output (Reserved)	
Controls			

Type	Qty	Description
ETHERNET	2	Gigabit Ethernet control ports. Support TCP/IP protocol and star topology. They have the same functions without priority and order, and can be connected to VMP software. No switch or router is needed to deploy multiple devices on the same LAN via device cascading as the network switching function is already built in. Up to 20 CX40 Pro devices can be cascaded.
GENLOCK	1	A pair of Genlock signal connectors. Support Bi-Level, Tri-Level, and Blackburst. <ul style="list-style-type: none"> • IN: Accept the sync signal. • LOOP: Loop the sync signal. The Genlock input signal supports a frame rate range from 23.98 Hz to 60 Hz. For standard Genlock signal generators, up to 20 CX40 Pro devices can be cascaded.
AUX	1	An auxiliary port that connects to the central control device (RS232) (Reserved)
Power		
100-240V~, 50/60Hz, 1.5A	1	An AC power input connector and switch

 **Note**

The width of HDMI and DP input sources must be an integer multiple of four. In addition, the maximum input resolution and maximum width and height must be obtained by setting the graphics card.

Dimensions

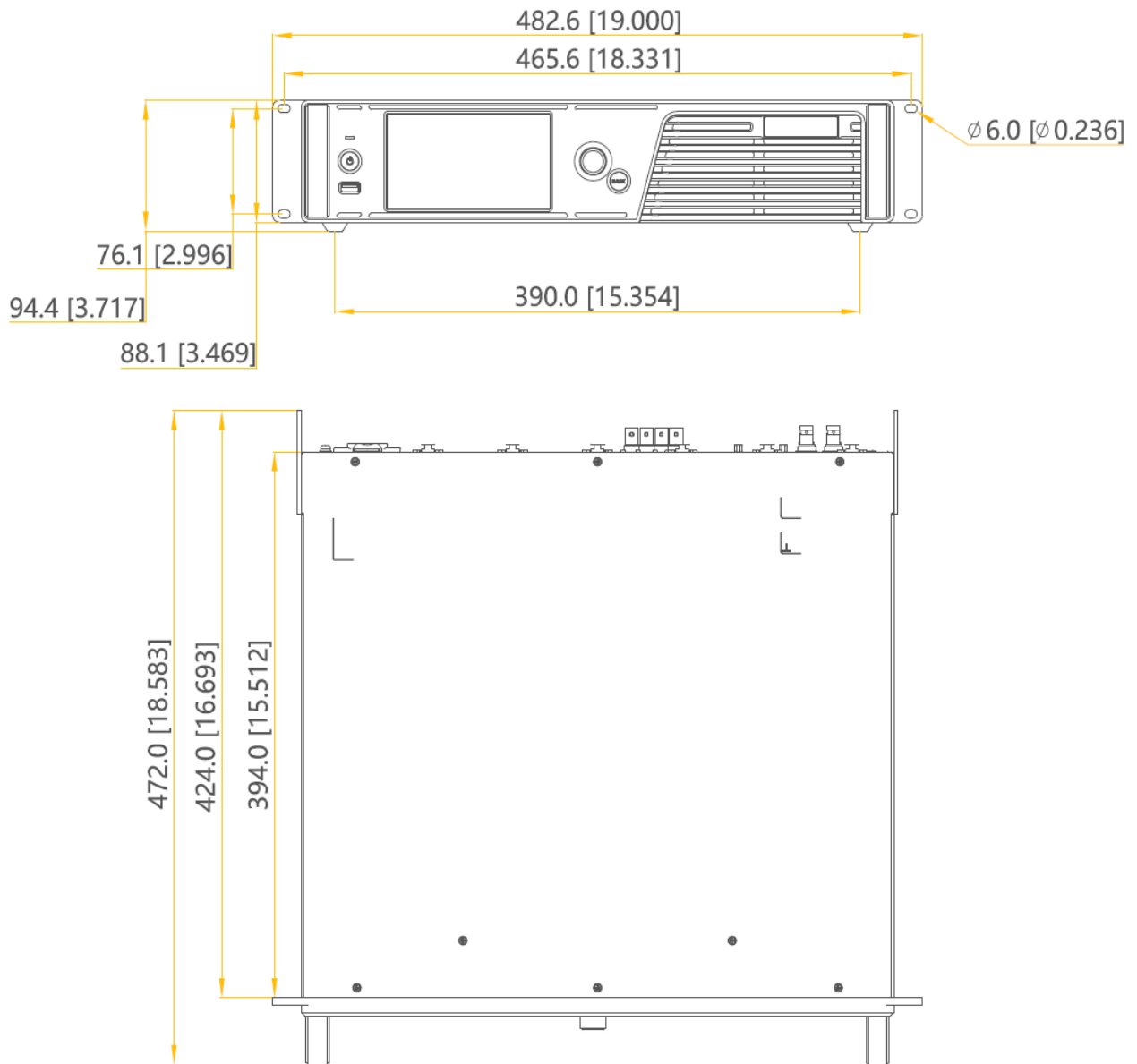

Tolerance: ± 0.3 [± 0.012] Unit: mm [inch]

Product Specifications

Electrical Specifications	Power supply	AC 100-240V~, 50/60Hz, 1.5A
	Power consumption	105 W
Operating Environment	Temperature	-10°C to +45°C
	Humidity	0% RH to 80% RH, non-condensing
Storage Environment	Temperature	-30°C to +80°C
	Humidity	0% RH to 95% RH, non-condensing
Physical Specifications	Dimensions	482.6 mm x 94.4 mm x 472.0 mm
	Net weight	8.1 kg

	Gross weight	11.1 kg Note: It is the total weight of the product, accessories, and packing materials packed according to the packing specifications.
Packing Information	Packing box	660.0 mm × 570.0 mm × 210.0 mm, kraft paper box
	Accessory box	408.0 mm × 290.0 mm × 50.0 mm, white cardboard box
	Accessories	<ul style="list-style-type: none"> • 1x Power cord • 1x Ethernet cable • 1x HDMI cable • 1x DP cable • 1x Certificate of Approval
IP Rating	IP20 (Please prevent the product from water intrusion and do not wet or wash the product).	
Noise Level (typical at 25°C/77°F)	45 dB (A)	

The amount of power consumption may vary depending on various factors such as product settings, usage, and environment.

Video Source Specifications

Input	Resolution		Color Space	Sampling	Bit Depth	Integer Frame Rate (Hz)
HDMI 2.0	4K	4096×2160 (Forced)	RGB / YCbCr	4:4:4	12bit	24/25/30
					10bit	24/25/30/48/50
					8bit	24/25/30/48/50/60
			YCbCr	4:2:2	8/10/12bit	
		3840×2160	RGB / YCbCr	4:4:4	12bit	24/25/30
					10bit	24/25/30/48/50
	8bit				24/25/30/48/50/60	
		YCbCr	4:2:2	8/10/12bit		
	2K/1K	2560×1440	RGB / YCbCr	4:4:4	12bit	24/25/30/48/50/60/75
					10bit	24/25/30/48/50/60/75/100
					8bit	24/25/30/48/50/60/75/100/120
			YCbCr	4:2:2	8/10/12bit	
1920×1080		RGB / YCbCr	4:4:4	12bit	24/25/30/48/50/60/72/75/100/120/144	
				10bit		
	8bit			24/25/30/48/50/60/72/75/100/120/144/240		
	YCbCr	4:2:2	8/10/12bit	(240 Hz needs to be forced)		

Input	Resolution		Color Space	Sampling	Bit Depth	Integer Frame Rate (Hz)			
DP 1.2	4K	4096x2160 (Forced)	RGB / YCbCr	4:4:4	12bit	24/25/30/48/50			
					10bit	24/25/30/48/50/60			
					8bit	24/25/30/48/50/60/75			
		YCbCr	4:2:2	8/10/12bit					
		3840x2160	RGB / YCbCr	4:4:4	12bit	24/25/30/48/50			
					10bit	24/25/30/48/50/60			
	8bit				24/25/30/48/50/60/75				
	YCbCr	4:2:2	8/10/12bit	(75 Hz needs to be forced)					
				2K1K	2560x1440	RGB / YCbCr	4:4:4	12bit	24/25/30/48/50/60/75/100
								10bit	24/25/30/48/50/60/75/100/120
	8bit	24/25/30/48/50/60/75/100/120/144 (144 Hz needs to be forced)							
	YCbCr	4:2:2	8/10/12bit	(144 Hz needs to be forced)					
1920x1080				RGB / YCbCr	4:4:4	12bit	24/25/30/48/50/60/75/100/120/144 (144 Hz needs to be forced)		
						10bit			
	8bit	24/25/30/48/50/60/75/100/120/144/ 240 (240 Hz needs to be forced)							
YCbCr	4:2:2	8/10/12bit	(240 Hz needs to be forced)						
			12G-SDI	4K	4096x2160	YCbCr	4:2:2	10bit	24/25/30/48/50/60
					3840x2160				
2K1K	2048x1080								
	1920x1080								

Note

The table above only displays a selection of common resolutions and integer frame rates. Decimal frame rates are also supported, allowing for automatic frame rate adaptation from the highest frame rate of each resolution down to 23.98/29.97/47.95/59.94/71.93/119.88/143.86 Hz.

Ethernet Port Load Capacity

When the CX40 Pro works with the CA50E and XA50 Pro receiving cards, the formula of calculating the load capacity per Ethernet port and the detailed parameters are as follows.

- 8bit: Load capacity $\times 24 \times$ Frame rate $< 5G \times 0.85$
- 10bit: Load capacity $\times 32 \times$ Frame rate $< 5G \times 0.85$
- 12bit: Load capacity $\times 36 \times$ Frame rate $< 5G \times 0.85$

Note

The device can only reach its maximum load capacity when the load width of a single port is 192 or greater. If the load width is smaller, some of the load capacity will be lost.

Max Load Capacity per Ethernet Port (Pixels)			
Frame Rate / Bit Depth	8bit	10bit	12bit
24 Hz	7,378,000	5,533,000	3,689,000
25 Hz	7,082,800	5,311,680	3,541,440
30 Hz	5,902,400	4,426,400	2,951,200
50 Hz	3,541,440	2,655,840	1,770,720
60 Hz	2,951,200	2,213,200	1,475,600
120 Hz	1,475,600	1,106,600	737,800
144 Hz	1,229,600	918,478	612,374
240 Hz	737,800	553,300	368,900

Notes and Cautions

Notes for Battery

- The battery is not intended to be replaced.
- Disposal of a battery into fire or a hot oven, or mechanically crushing or cutting of a battery can result in an explosion.
- Leaving a battery in an extremely high temperature surrounding environment can result in an explosion or the leakage of flammable liquid or gas.
- A battery subjected to extremely low air pressure may result in an explosion or the leakage of flammable liquid or gas.

Notes for Installation

When the product needs to be installed on the rack, 4 screws at least M5*12 should be used to fix it. The rack for installation shall bear at least 32.4 kg weight.

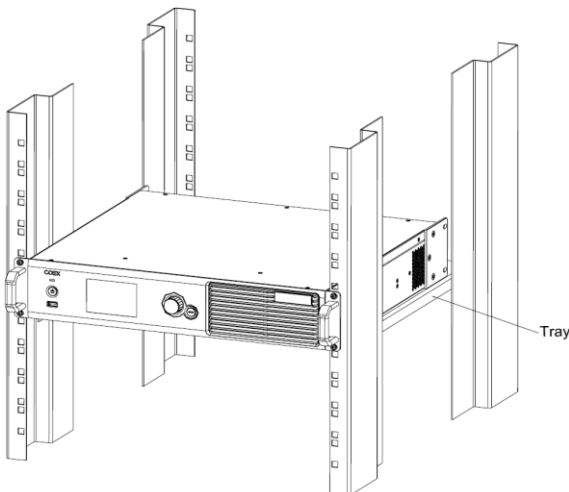

- Elevated Operating Ambient - If installed in a closed or multi-unit rack assembly, the operating ambient temperature of the rack environment may be greater than room ambient. Therefore, consideration should be given to installing the equipment in an environment compatible with the maximum ambient temperature (T_{ma}) specified by the manufacturer.
- Reduced Air Flow – Installation of the equipment in a rack should be such that the amount of air flow required for safe operation of the equipment is not compromised.

- Mechanical Loading – Mounting of the equipment in the rack should be such that a hazardous condition is not achieved due to uneven mechanical loading.
- Circuit Overloading – Consideration should be given to the connection of the equipment to the supply circuit and the effect that overloading of the circuits might have on overcurrent protection and supply wiring. Appropriate consideration of equipment nameplate ratings should be used when addressing this concern.
- Reliable Earthing – Reliable earthing of rack-mounted equipment should be maintained. Particular attention should be given to supply connections other than direct connections to the branch circuit (e.g. use of power strips).

FCC Caution

Any changes or modifications not expressly approved by the party responsible for compliance could void the user's authority to operate the equipment.

This device complies with part 15 of the FCC Rules. Operation is subject to the following two conditions: (1) This device may not cause harmful interference, and (2) this device must accept any interference received, including interference that may cause undesired operation.

Note: This equipment has been tested and found to comply with the limits for a Class A digital device, pursuant to part 15 of the FCC Rules. These limits are designed to provide reasonable protection against harmful interference when the equipment is operated in a commercial environment. This equipment generates, uses, and can radiate radio frequency energy and, if not installed and used in accordance with the instruction manual, may cause harmful interference to radio communications. Operation of this equipment in a residential area is likely to cause harmful interference in which case the user will be required to correct the interference at his own expense.

Others

This product can only be placed horizontally. Do not mount vertically or upside-down.

This is Class A product. In a domestic environment, this product may cause radio interference in which case the user may be required to take adequate measures.

TECNOGROUP
LED TECHNOLOGY EXPERTS

Tel: +56 9 5449 1032
Email: contacto@tecnogroup.cl

Casa Matriz
Padre Hurtado Central 580
Las Condes, Santiago de Chile

www.tecnogroup.cl

 @tecnogroup.cl  #tecnogroup.cl  Tecnogroup Chile

Tel: 833 533 4255
Email: info@tecnogroup.us

Showroom Miami
759 NW. 24th ST.
Miami, FL 33127

www.tecnogroup.us

 @tecnogroup.us  #tecnogroup.us  Tecnogroup USA